



Screens
and *Projector*
Lifts

**PROFESSIONAL
HOME THEATRE**



**TAILORED
FOR YOU**



English version

**GENERAL CATALOGUE
2025-2026**

INDEX

MOTORIZED SCREENS p. 2

Compact
Major

DESIGN MOTORIZED SCREENS p. 3

Tiziano

INCEILING MOTORIZED SCREENS p. 4

Giotto
Raffaello

LARGE MOTORIZED SCREENS p. 5-6

Open Roll
Major Pro-C
Major Pro-C Tensioned
Cine Pro

FLOOR RISING MOTORIZED SCREENS p. 7

DaVinci Ascender

FRAME SCREENS p. 8-9

Flat Elastic
Modigliani
Canaletto Elastic
Canaletto Wrap Around

DESIGN FRAME SCREENS p. 10

Leonardo FR14
Leonardo FR37

LARGE FRAME SCREENS p. 11

Flatmax
Flatmax Wrap Around

LARGE CURVED FRAME SCREENS p. 12

Arc Wrap Around

PORTABLE FRAME SCREENS p. 13

FlexFix

MOTORIZED PROJECTOR LIFTS p. 14

SI Models
SI-H L Models
SI-H XL Models

SCREEN WINCH SYSTEMS p. 15

For Compact
For Major
For Major Pro-C

ACCESSORIES p. 16

LARGE PROJECTION CLOTHS WITH EYELETS p. 17

PROJECTION SURFACES p. 17



ITALIAN
Design

From 160 cm. up to 450 cm.

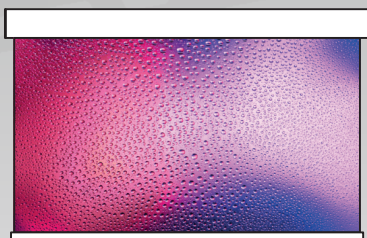

PROFESSIONAL

Motorized screen completely white with white dowel bar of high quality standards, silent system of fabric dragging and versatility under different projection conditions.

From 160 cm. up to 450 cm.

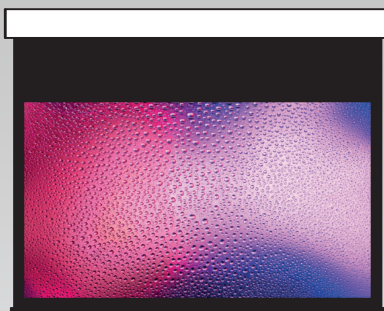

HOME CINEMA

Motorized screen with black side borders, black top drop and black dowel bar dedicated to both Home Theatre and AV Professional use.

From 160 cm. up to 400 cm.

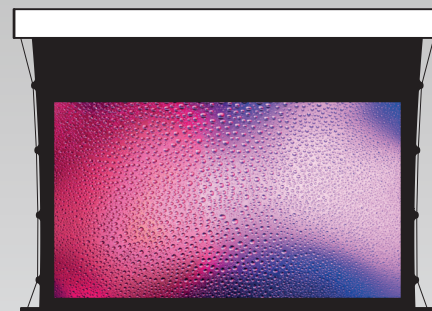

TENSIONED

Motorized screen with tab tensioned black side borders, black top drop and black dowel bar. This is the flagship needed to project a perfect image. It is dedicated to both Home Theatre and AV Professional use.

COMPACT

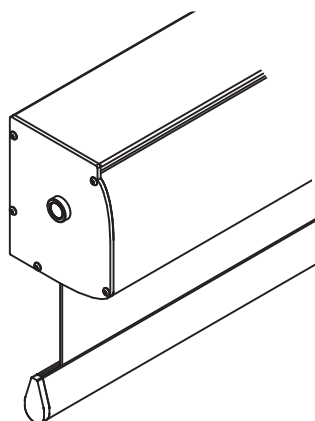

MAJOR

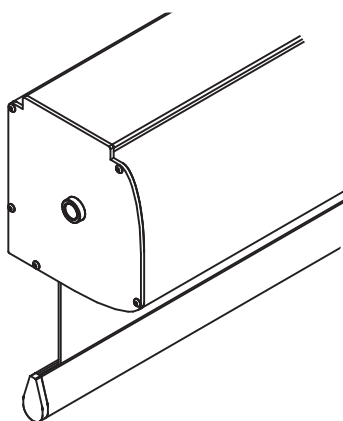

Learn more
about the product



- **COMPACT** from 160 cm. up to 300 cm. width
- **MAJOR** from 300 cm. up to 450 cm. width
- Available in all aspect ratios
- Wide range of projection surfaces available (front projection, ALR, acoustic and rear projection) - certified fire proof
- Easy to install manufactured with aluminum housing painted with white epoxy powders (RAL 9010)
- **Custom colours** of screen housing and dowel bar (*optional*)
- **Bespoke sizes, black borders and larger black top drop** (*optional*)

TARGET MARKETS



HOME
CINEMA



ENTERTAINMENT



MUSEUMS



EDUCATIONAL



CORPORATE



HOSPITALITY



PLACES OF
WORSHIP



SPECIAL
PROJECTS



LEISURE



RETAIL

From 160 cm. up to 400 cm.

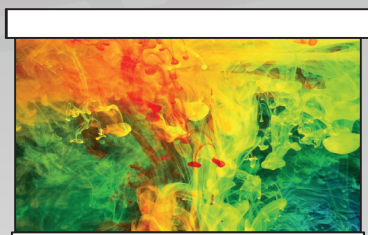

PROFESSIONAL

Stunning Italian design motorized screen completely white with white dowel bar of high quality standards, extremely silent motor and versatility under different projection conditions.

From 160 cm. up to 400 cm.

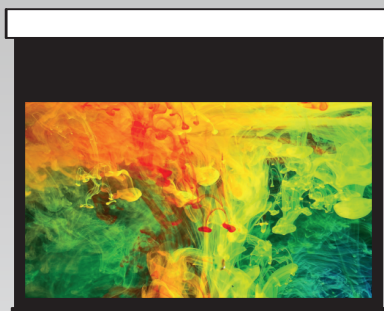

HOME CINEMA

Stunning Italian design motorized screen with black side borders, black top drop and black dowel bar ideal for high-end installations both for Home Theatre and AV Professional environments.

From 160 cm. up to 400 cm.

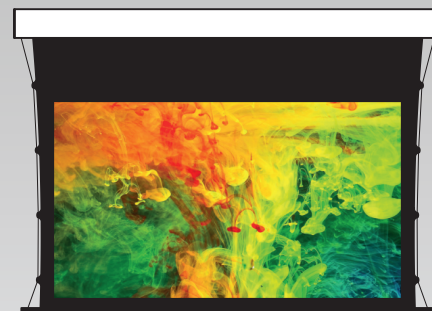

TENSIONED

Refined Italian design motorized screen with tab tensioned black side borders, black top drop and black dowel bar. The tensioned mechanism assures to this flagship model an absolutely perfect flatness of the projection surface.

TIZIANO

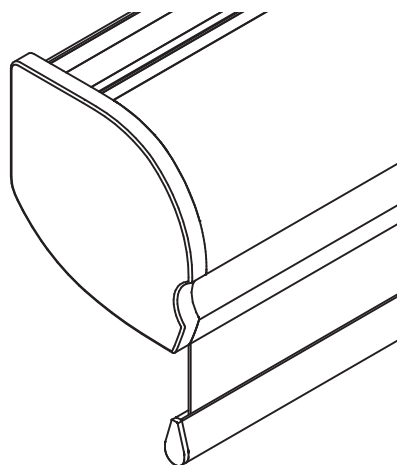

Learn more
about the product



- Available in all aspect ratios
- Wide range of projection surfaces available (front projection, ALR, acoustic and rear projection) - certified fire proof
- Easy to install, manufactured with aluminum housing painted with white epoxy powders (RAL 9016)
- Equipped with very quiet motor
- Invisible wall mounting brackets and hidden power cable
- Cloth drops down from the **front side** of the housing, spaced from the wall
- Tiziano Tensioned model with **VERY HIGH BLACK TOP DROP** available (*optional*)
- **Custom colours** of screen housing and dowel bar (*optional*)
- **Bespoke sizes, black borders and larger black top drop** (*optional*)

TARGET MARKETS



HOME
CINEMA



ENTERTAINMENT



MUSEUMS



EDUCATIONAL



CORPORATE



HOSPITALITY



PLACES OF
WORSHIP



SPECIAL
PROJECTS



LEISURE



RETAIL

INCEILING MOTORIZED SCREENS

GIOTTO RAFFAELLO

Giotto from 160 cm. up to 450 cm.
Raffaello from 160 cm. up to 400 cm.

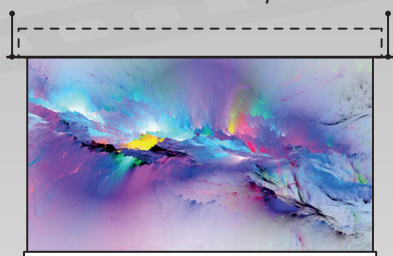

PROFESSIONAL

Giotto and Raffaello are in ceiling Italian design motorized screens completely white with white dowel bar that offers a hidden solution flushed inside the false ceiling.

Raffaello differentiates from Giotto as it offers no visible openings with closed trap door.

Giotto from 160 cm. up to 450 cm.
Raffaello from 160 cm. up to 400 cm.

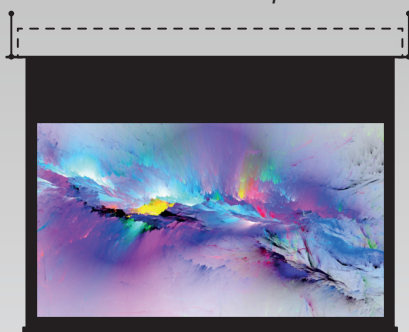

HOME CINEMA

Giotto and Raffaello are both in ceiling Italian design motorized screens with black side borders, black top drop and black dowel bar ideal for high-end installations both for Home Theatre and AV Professional environments.

Giotto from 160 cm. up to 400 cm.
Raffaello from 160 cm. up to 350 cm.



TENSIONED

Giotto and Raffaello are both in ceiling Italian design motorized screens with tab tensioned black side borders, black top drop and black dowel bar. The tensioned mechanism assures an absolutely perfect flatness of the projection surface.

GIOTTO

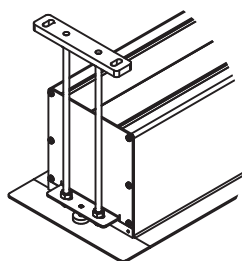

RAFFAELLO

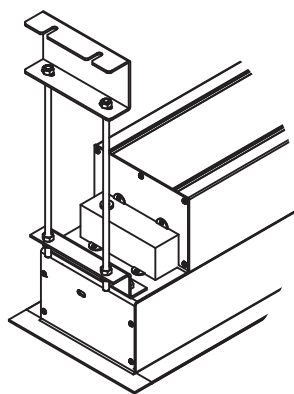

Learn more
about the product



- **GIOTTO** model is an in ceiling screen with a slim open slot from where the surface drop down
- **RAFFAELLO** model offers an elegant solution with a unique **motorized trap door** that **closes completely** the housing when the screen is retracted
- Available in all aspect ratios
- Wide range of projection surfaces available (front projection, ALR, acoustic and rear projection) – certified fire proof
- Manufactured with aluminum housing painted with white epoxy powders (RAL 9010)
- **Easy substitution of the roller tube** which offers the possibility to install the roller tube with the cloth after the installation is finished
- Giotto and Raffaello Tensioned are available with **VERY HIGH BLACK TOP DROP** (optional)
- **Custom colours** of screen housing and dowel bar (optional)
- **Bespoke sizes, black borders and larger black top drop** (optional)

TARGET MARKETS



HOME
CINEMA



ENTERTAINMENT



MUSEUMS



EDUCATIONAL



CORPORATE



HOSPITALITY



PLACES OF
WORSHIP



SPECIAL
PROJECTS



LEISURE



RETAIL

LARGE MOTORIZED SCREENS

OPEN ROLL MAJOR PRO-C MAJOR PRO-C TENSIONED

from 500 cm. up to 700 cm.

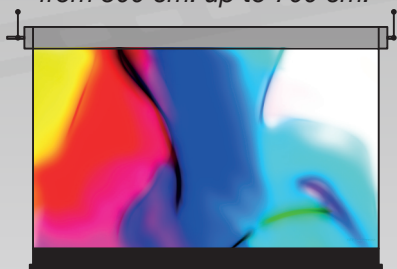

from 500 cm. up to 700 cm.

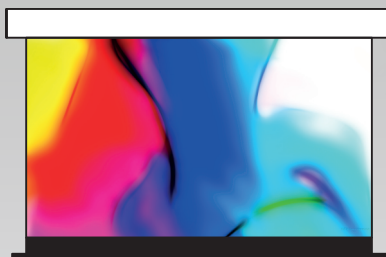

from 450 cm. up to 650 cm.

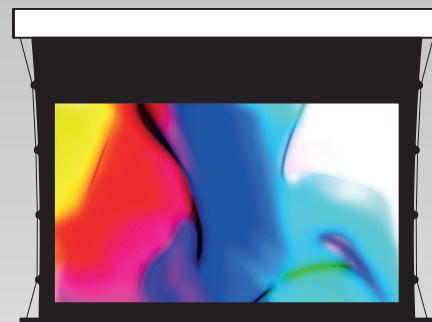

OPEN ROLL

Large motorized screen with an open mechanism without the housing ideally for large ambients like auditoriums, concert halls, conference rooms where large projections are needed.

MAJOR PRO-C

Big motorized screen with large aluminum housing, specifically designed for videoprojections in large environments like universities, multipurpose halls and conference centres.

MAJOR PRO-C TENSIONED

Big motorized screen with sturdy aluminum housing, tab tensioned black side borders, black top drop and black dowel bar, ideal solution for a perfect projection image in large environments.

OPEN ROLL

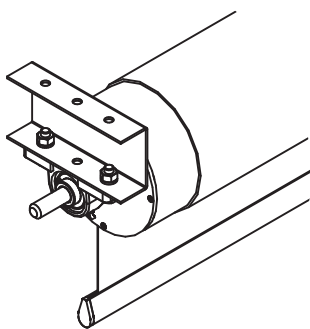

MAJOR PRO-C MAJOR PRO-C TENSIONED

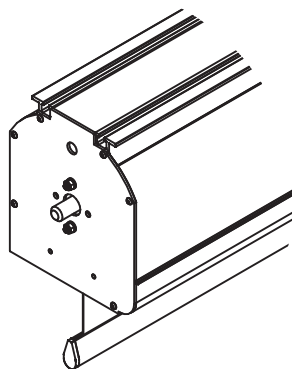

Learn more
about the product



- **OPEN ROLL** from 500 cm. up to 700 cm. width – open mechanism without housing
- **MAJOR PRO-C** from 500 cm. up to 700 cm. width – with housing
- **MAJOR PRO-C TENSIONED** from 450 cm. up to 650 cm. width – with housing
- Available in all aspect ratios
- Wide range of projection surfaces available (front projection, acoustic and rear projection) – certified fire proof
- Major Pro-C models equipped with aluminum housing painted with white epoxy powders (RAL 9010)
- Inceiling solution available (*optional*)
- **Custom colours** of screen housing and dowel bar (*optional*)
- **Bespoke sizes, black borders and larger black top drop** (*optional*)

TARGET MARKETS



TAILORED
FOR YOU



from 800 cm. up to 1200 cm.



CINE PRO

Cine Pro is a motorized electric **bottom roller** screen available up to 12 m. of width. This is the ideal product for large environments like cinemas, theatres, auditoriums where there is the need to join a projection with the alternative to play a performance on the stage.

CINE PRO

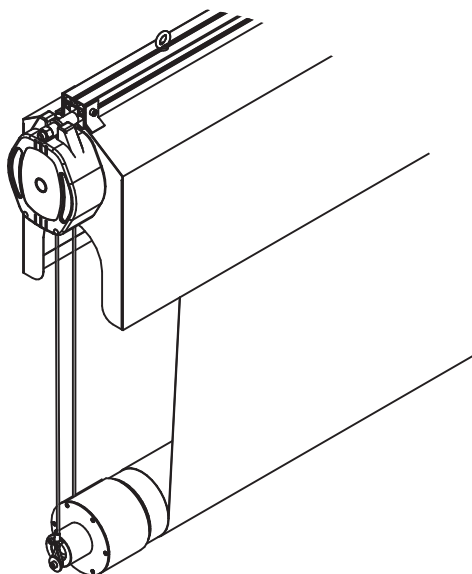

Learn more
about the product



- Electric **BOTTOM ROLLER** screen from 8 m. up till 12 m. width that assures perfect flatness
- Available in 16:10, 16:9 and 21:9 aspect ratios
- Wide range of projection surfaces available (front projection, acoustic and rear projection) – certified fire proof
- Safer descent of the roller thanks to the steel cables and additional new **SAFETY MECHANISM** which **stops motor in case an obstacle is hit** during rolling down
- Equipped with **SAFETY SYSTEM** at both sides that prevents dropping down of the bottom roller in case of failure
- **Bespoke sizes, black borders and black top drop** (optional)

TARGET MARKETS



ENTERTAINMENT



MUSEUMS



EDUCATIONAL



CORPORATE



HOSPITALITY



PLACES OF
WORSHIP



SPECIAL
PROJECTS



LEISURE



RETAIL

FLOOR RISING MOTORIZED SCREENS

DAVINCI ASCENDER



DAVINCI ASCENDER

DaVinci Ascender is the ScreenInt® **tensioned floor-rising motorized** projection screen that rises smoothly and elegantly from the floor, creating a polished and professional aesthetic for your projection, that can also be integrated into a furniture.

DAVINCI ASCENDER

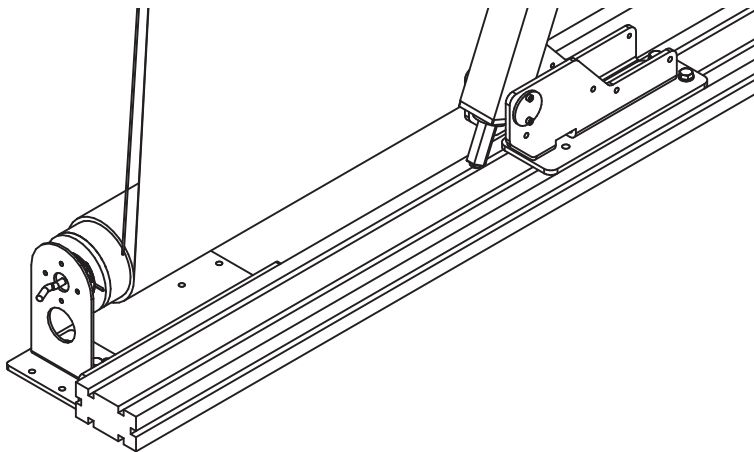

Learn more
about the product



- **FLOOR RISING** motorized screen from 220 cm. up till 400 cm. of width
- Available in 16:10, 16:9 and 21:9 aspect ratios
- Wide range of projection surfaces available (front projection, acoustic and ALR) - certified fire proof
- Side borders with a specific tensioning system
- Unique rear scissors system that provides smooth rising up from the floor and perfect flatness of the surface
- **Bespoke sizes and black bottom drop** (optional)

TARGET MARKETS



HOME
CINEMA



ENTERTAINMENT



MUSEUMS



EDUCATIONAL



CORPORATE



HOSPITALITY



PLACES OF
WORSHIP



SPECIAL
PROJECTS



LEISURE



RETAIL

TAILORED
FOR YOU



from 160 cm. up to 400 cm.



FLAT ELASTIC

Fixed frame screen with a professional aluminum black frame that can be installed within any environment.

from 160 cm. up to 300 cm.



MODIGLIANI

Fixed frame screen with a rounded design frame, which assures a smart aesthetic look once installed.

MODIGLIANI VELVET

This frame screen has the shape of the Modigliani screen with the velvet finishing that gives a touch of elegance to the product.

FLAT ELASTIC

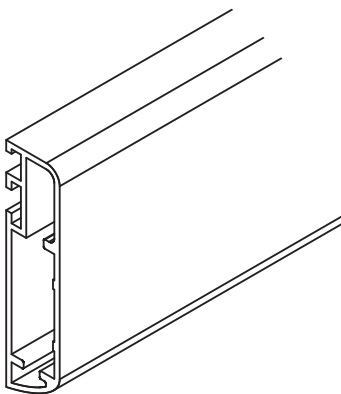

MODIGLIANI MODIGLIANI VELVET

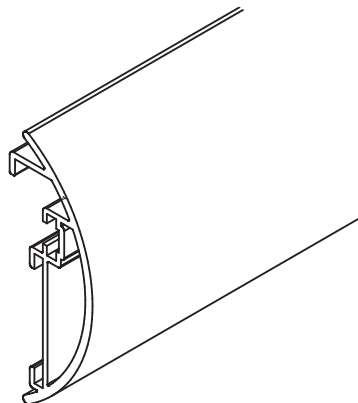

Learn more
about the product



- **FLAT ELASTIC** from 160 cm. up to 400 cm. width
- **MODIGLIANI** from 160 cm. up to 300 cm. width
- **MODIGLIANI VELVET** from 160 cm. up to 300 cm. width
- Available in all aspect ratios
- Wide range of projection surfaces available (front projection, ALR, acoustic and rear projection) – certified fire proof
- Flat Elastic and Modigliani aluminum frame painted with black dull epoxy powders (RAL 9005)
- Modigliani Velvet aluminum frame covered with black velvet
- Easy and quick fixing of the projection surface onto the frame by rubber bands
- For **Flat Elastic**, ruggedized **floorstands** available (*optional*)
- **Bespoke sizes** (*optional*)

TARGET MARKETS



HOME
CINEMA



ENTERTAINMENT



MUSEUMS



EDUCATIONAL



CORPORATE



HOSPITALITY



PLACES OF
WORSHIP



SPECIAL
PROJECTS



LEISURE



RETAIL

CANALETTO ELASTIC CANALETTO WRAP AROUND

from 160 cm. up to 400 cm.



CANALETTO ELASTIC

Exclusive design aluminum frame screen with velvet border on the frame surrounding the viewing area that can be a smart aesthetic solution for every installation.

from 160 cm. up to 400 cm.

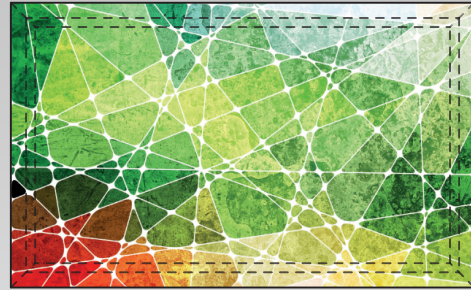

CANALETTO WRAP AROUND

Completely white frame screen with projection surface wrapped around the Canaletto frame, which results in a borderless screen.

CANALETTO ELASTIC

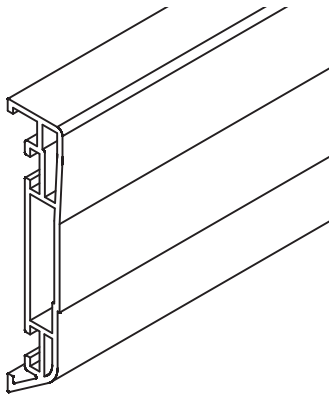

CANALETTO WRAP AROUND

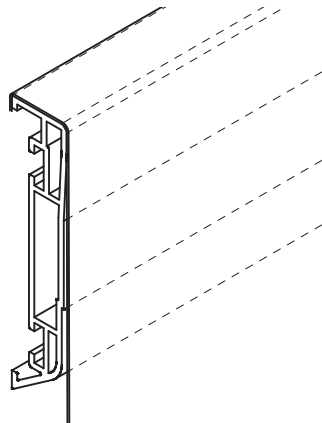

Learn more
about the product



- **CANALETTO ELASTIC** from 160 cm. up to 400 cm. width
- **CANALETTO WRAP AROUND** from 160 cm. up to 400 cm. width
- Available in all aspect ratios
- Wide range of projection surfaces available (front projection, ALR, UST, acoustic and rear projection) – certified fire proof
- Canaletto Elastic aluminum frame painted with black dull epoxy powders (RAL 9005) with internal velvet border that surrounds the viewing area
- On **Canaletto Elastic** fixing of the projection surface onto the frame by rubber bands
- On **Canaletto Wrap Around** fixing of the projection surface onto the frame by Velcro strips
- For **Canaletto Elastic**, ruggedized **floorstands** available (*optional*)
- **Bespoke sizes** (*optional*)

TARGET MARKETS



HOME
CINEMA



ENTERTAINMENT



MUSEUMS



EDUCATIONAL



CORPORATE



HOSPITALITY



PLACES OF
WORSHIP



SPECIAL
PROJECTS



LEISURE



RETAIL

TAILORED
FOR YOU



from 160 cm. up to 400 cm.

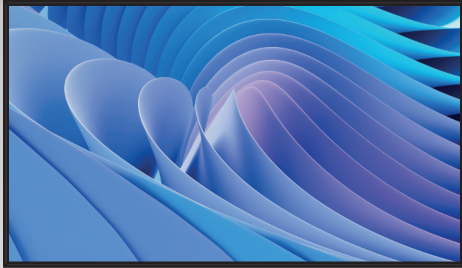

LEONARDO FR14

Innovative design aluminum frame screen with extremely thin velvet bezel that aims to satisfy the most demanding requirements in terms of design and aesthetics.
Bezel width 14 mm. only.

from 160 cm. up to 400 cm.

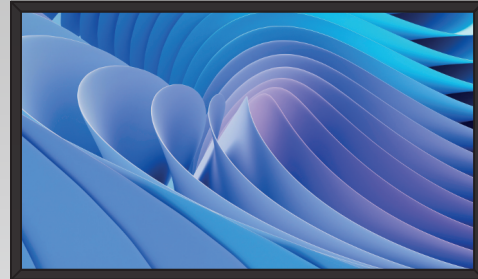

LEONARDO FR37

Innovative design aluminum frame screen with thin velvet bezel which gives it a touch of elegance.
Bezel width 37 mm. only.

LEONARDO FR 14

LEONARDO FR37

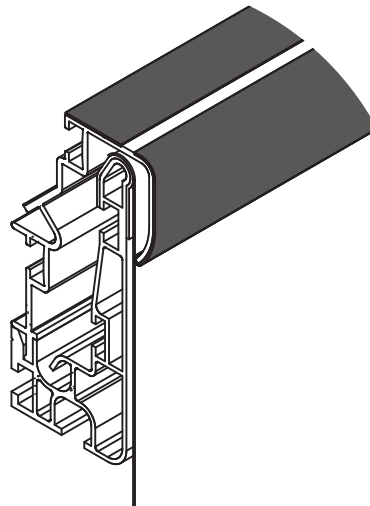
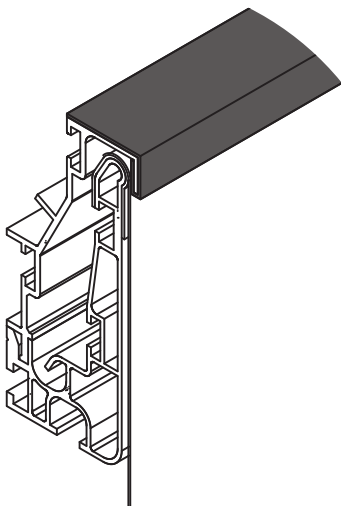

Learn more
about the product



- **LEONARDO FR14** from 160 cm. up to 400 cm. width
- **LEONARDO FR37** from 160 cm. up to 400 cm. width
- Available in all aspect ratios
- Wide range of projection surfaces available (front projection, ALR, UST and acoustic) – certified fire proof
- Ruggedized aluminum frame covered with black thin velvet bezel
- Easy and quick fixing of the projection surface onto the frame by rubber bands
- **Bespoke sizes (optional)**

TARGET MARKETS



HOME CINEMA



ENTERTAINMENT



MUSEUMS



EDUCATIONAL



CORPORATE



HOSPITALITY



PLACES OF WORSHIP



SPECIAL PROJECTS



LEISURE



RETAIL

LARGE FRAME SCREENS

FLATMAX FLATMAX WRAP AROUND

from 500 cm. up to 1500 cm.



FLATMAX

Sturdy aluminum frame screen suitable for manufacturing very large screens for fixed installations.

from 500 cm. up to 1500 cm.

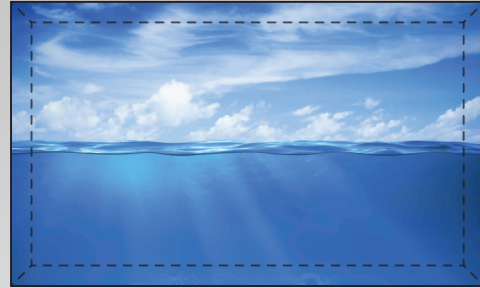

FLATMAX WRAP AROUND

Completely white frame screen with projection surface wrapped around the Flatmax frame, which results in a borderless screen, suitable for fixed installations.

FLATMAX

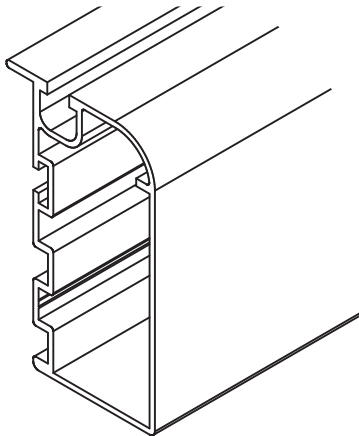

FLATMAX WRAP AROUND

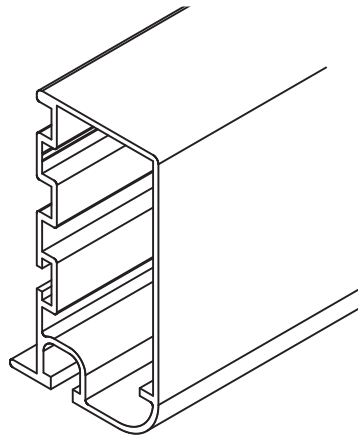

Learn more
about the product



- **FLATMAX** from 500 cm. up to 1500 cm. width
- **FLATMAX WRAP AROUND** from 500 cm. up to 1500 cm. width
- Available in all aspect ratios
- Wide range of projection surfaces available (front projection, acoustic and rear projection) – certified fire proof
- Flatmax aluminum frame painted with black dull epoxy powders (RAL 9005)
- Easy and quick fixing of the projection surface onto the frame by rubber bands
- Ruggedized **floorstands** available (*optional*)
- Bracing bars available for hanging the screen from the ceiling (*optional*)
- Truss mounting brackets (*optional*)
- **Bespoke sizes** (*optional*)

TARGET MARKETS



ENTERTAINMENT



MUSEUMS



EDUCATIONAL



CORPORATE



HOSPITALITY



SIMULATORS



PLACES OF
WORSHIP



SPECIAL
PROJECTS



LEISURE



RETAIL

TAILORED
FOR YOU





The Arc Wrap Around is a frame screen developed to obtain curved screens up to 360°. It is an excellent solution for large applications like theme parks, museums, virtual production, simulation rooms for automotive, industrial applications or medical purposes.

ARC WRAP AROUND

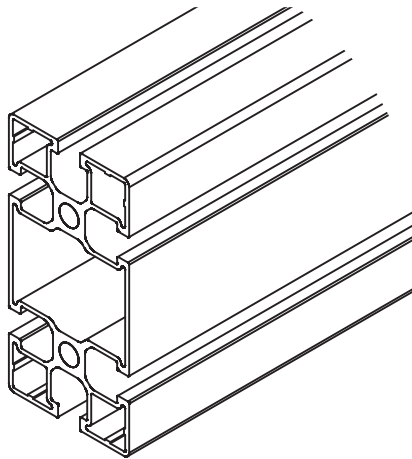

*Learn more
about the product*



- **ARC WRAP AROUND** from 300 cm. up to 2500 cm. width
- Minimum curve radius 300 cm.
- Self standing screen equipped with **ruggedized floorstands**
- Wide range of projection surfaces available (front projection, acoustic and rear projection) – certified fire proof
- Sturdy aluminum frame with projection surface wrapped around
- Easy and quick fixing of the projection surface onto the frame by rubber bands
- **Bespoke sizes** (*optional*)
- **Different curved shapes** (*optional*)

TARGET MARKETS



ENTERTAINMENT



MUSEUMS



EDUCATIONAL



CORPORATE



HOSPITALITY



SIMULATORS



PLACES OF
WORSHIP



SPECIAL
PROJECTS



LEISURE



RETAIL



The FlexFix is a portable frame screen ideal for rental, large events, houses of worship where an easy and quick set up is needed.

FLEXFIX

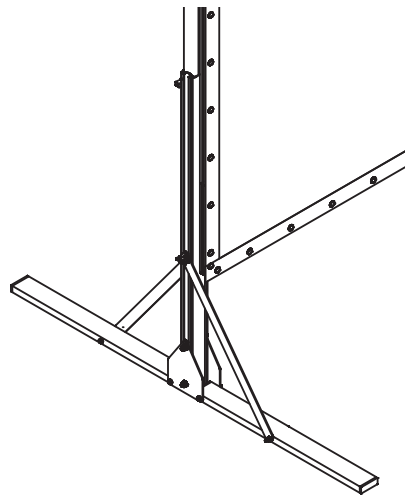
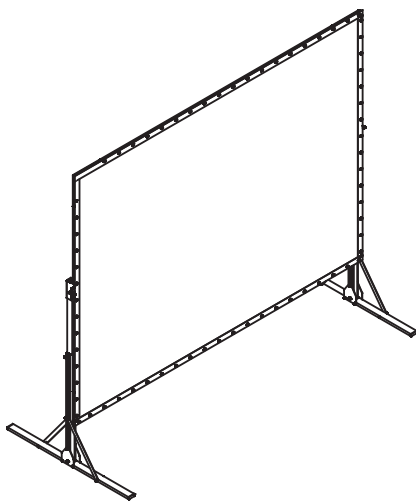

Learn more
about the product



- From 250 cm. up to 475 cm. width
- Available in 16:10 and 16:9 aspect ratios
- Self supporting screen supplied with sturdy T-Shape floorstands and carrying softbag
- Wide range of projection **SEAMLESS** surfaces available (front projection and rear projection) – certified fire proof
- Sturdy aluminum frame
- Easy and quick fixing of the projection surface onto the frame by **stud press buttons**
- Truss mounting brackets (*optional*)
- Hard wheeled carrying case (*optional*)
- Smart and ruggedized trolley bag (*optional*)

TARGET MARKETS



ENTERTAINMENT



MUSEUMS



EDUCATIONAL



CORPORATE



HOSPITALITY



PLACES OF
WORSHIP



SPECIAL
PROJECTS



LEISURE



RETAIL

MOTORIZED PROJECTOR LIFTS

SI Models SI-H L Models SI-H XL Models

SI Models

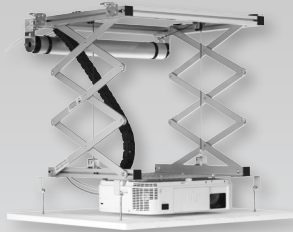

SI-30, SI-100, SI-200

SI-H L Models

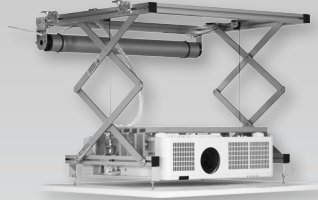

SI-H L 40 HC, SI-H L 50 HC
SI-H L 100, SI-H L 200, SI-H L 300

SI-H XL Models



SI-H XL 300
SI-H XL 500

Maximum load of 15 kg.
Different drop extensions from 48 cm.
up till 200 cm.

Maximum load of 30 kg.
Different drop extensions from 54 cm.
up till 300 cm.

Maximum load of 95 kg.
Different drop extensions from 60 cm.
up till 500 cm.

SI and SI-H L MODELS

- Equipped with a professional **cable gathering system**
- Supplied with **safety screws** that prevent the lift to extend further in case of failure
- **Extendable side brackets** with winded rods for an easy fixing of the false ceiling panel
- **Universal fixing system** to allow mounting of the majority of projector models
- Specific models for **very narrow false ceilings of only 14 cm.**
- Ceiling tile holder available for all lift models (*optional*)
- RF remote control kit (*optional*)
- Low voltage contact interface (*optional*)

SI-H XL MODELS

- Heavy duty lifts equipped with a professional **cable gathering system**
- Supplied with **safety system** that prevents accidents in case of failure
- **Motor with THREE adjustable limit stops:** upper, intermediate (projection mode) and bottom (service mode)
- **RF remote control** included
- **Universal fixing system** to allow mounting of the majority of large projector models
- Included with **three low voltage contact closure points**
- Ceiling tile holder available for all lift models (*optional*)

Learn more
about the product



TARGET MARKETS



HOME
CINEMA



ENTERTAINMENT



MUSEUMS



EDUCATIONAL



CORPORATE



HOSPITALITY



SIMULATORS



PLACES OF
WORSHIP



SPECIAL
PROJECTS



LEISURE



RETAIL

SCREEN WINCH SYSTEMS

for COMPACT for MAJOR for MAJOR PRO-C

FOR COMPACT



It is a screen lift for motorized screens up to 300 cm. of width, supplied with RF remote control and three low voltage contact closure points.

FOR MAJOR



It is a screen lift for motorized screens from 300 cm. up to 450 cm. of width, equipped with RF remote control and three low voltage contact closure points.

FOR MAJOR PRO-C



It is an heavy duty lift for motorized screens from 500 cm. up to 700 cm. of width, supplied with a double safety system.

*Learn more
about the product*



- Excellent stability of the screen housing when rolled down
- For all models: **maximum drop extension 700 cm.**
- All models are equipped with a sophisticated safety system
- All models are supplied with a cable coiler system that brings power to the screen
- SCREEN WINCH SYSTEMS for Compact and Major come with **RF remote control** and motor that includes **three low voltage contact closure points**
- SCREEN WINCH SYSTEMS for Major Pro-C have an additional new **SAFETY MECHANISM** which **stops motor in case an obstacle is hit during rolling down** which results in a safer descent of the screen

TARGET MARKETS



TAILORED
FOR YOU



ELECTRICAL ACCESSORIES

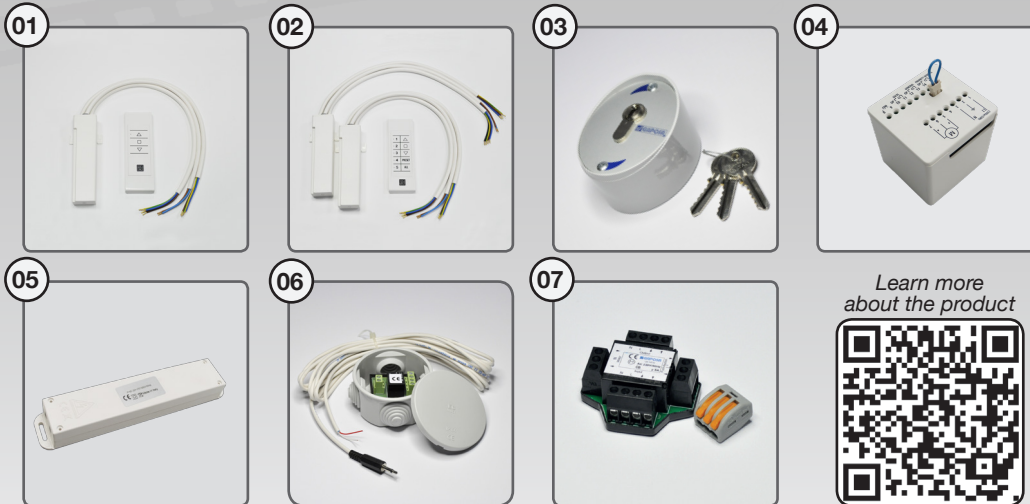

- 01- RF remote control kit
- 02- Multichannel RF remote control kit
- 03- Key operated switch
- 04- Low voltage contact interface
- 05- Interface RS 485
- 06- Interface switch 12 volt
- 07- Multiple control interface set

MECHANICAL ACCESSORIES

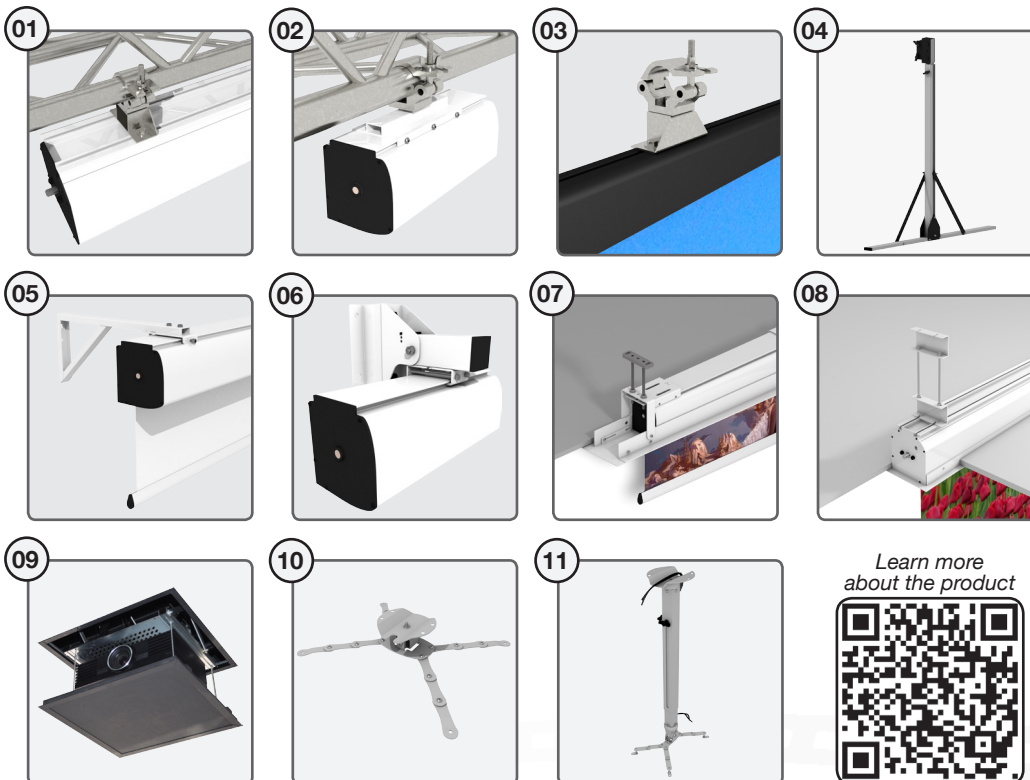

- 01- Truss mounting brackets for Major Pro-C
- 02- Truss mounting brackets for Compact and Major
- 03- Truss mounting brackets for Flatmax
- 04- Floorstands for frame screens
- 05- Wall extension brackets for Compact and Major
- 06- Sloping brackets for Compact, Major and Screen Winch System
- 07- False ceiling trim kit for Compact and Major
- 08- False ceiling trim kit for Major Pro-C
- 09- Ceiling tile holders for all lift models
- 10- Projector brackets: B-7 and B-24
- 11- Telescopic projector brackets: T-Medium and T-Long

LARGE PROJECTION CLOTHS WITH EYELETS

Very large surfaces with reinforced perimetral borders all around and eyelets every 20 cm.
Wide range of projection surfaces available (front projection, acoustic and rear projection) – Certified fire proof.

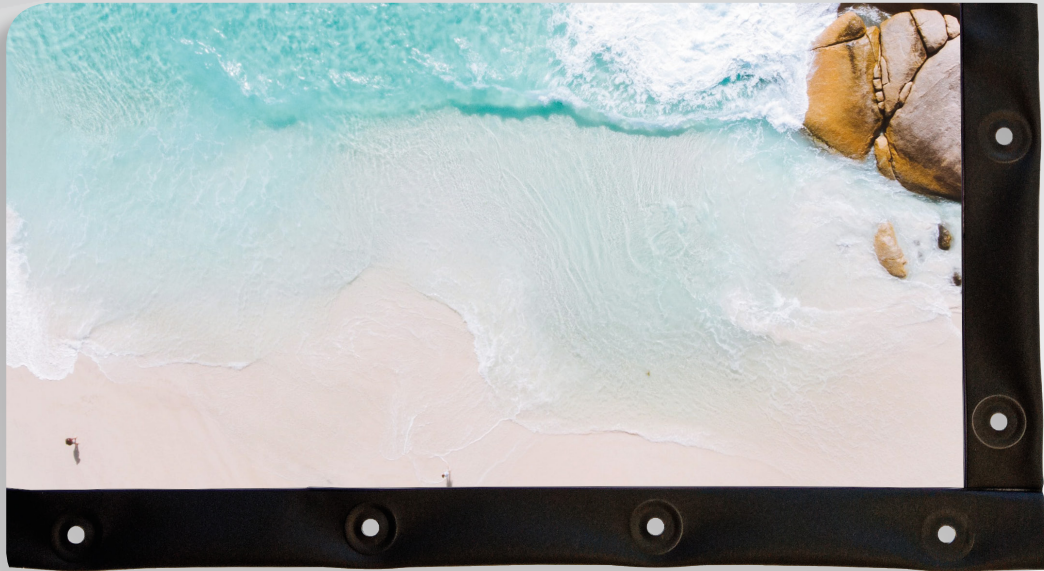

PROJECTION SURFACES

For all screens very wide range of projection surfaces available. See here under the technical features.

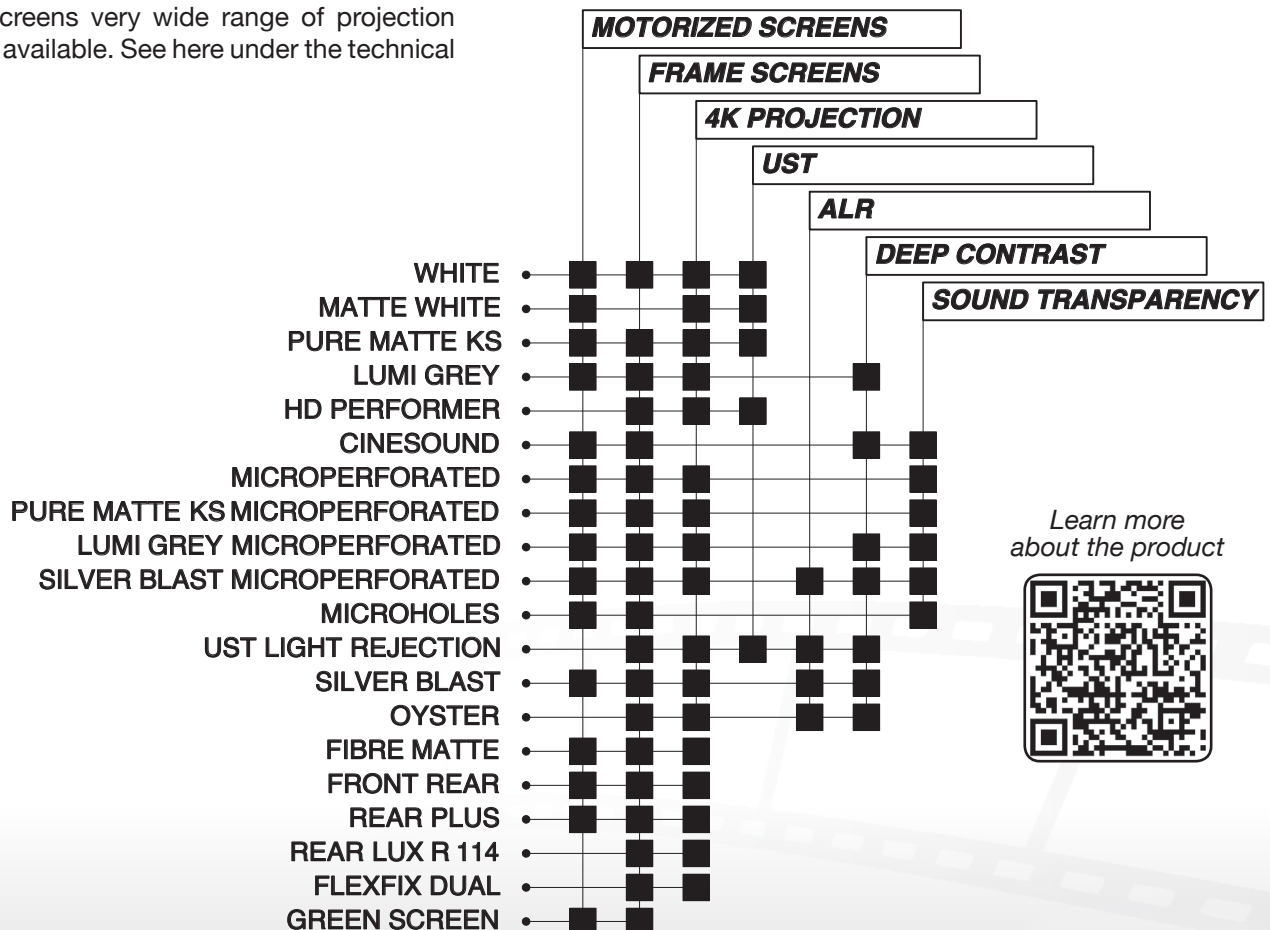

Learn more about the product

